

Original Dual control shower valve

ILLUSTRATION



FEATURES AND BENEFITS:

The Original collection of taps, mixers, accessories and shower fittings is exclusive to C.P. Hart. The range includes traditional as well as more contemporary-styled items. Brass or silver colour-way options and functionality such as the pop-up waste, ceramic-disc quarter turn technology, and easy-clean shields add further versatility.

AVAILABILITY/ PRODUCT CODES:

grordcsvcp Dual control shower valve

COMPATIBILITY:

Compatible for use with all C.P. Hart shower heads

CARE AND MAINTENANCE INSTRUCTIONS:

Clean with liquid detergent rinse and dry then buff with a soft lint free cloth. No abrasive cleaners should be used. Vinegar or limejuice can be used to remove stubborn limescale deposits.

INSTALLATION INFORMATION/ REQUIREMENTS:

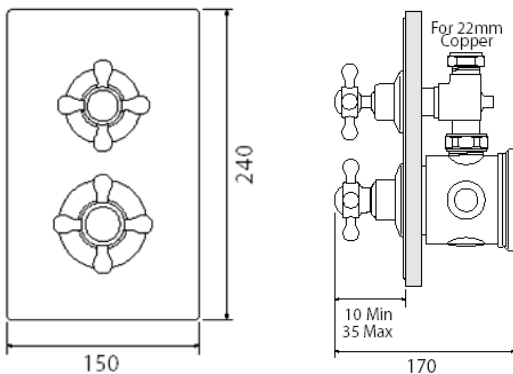

C.P. Hart cannot guarantee the accuracy of this information.

Dimensions are nominal – for guidance only and are not to be used for pre-installation.

For further information call Central Sales on 0845 600 1950
For projects & developments call the Contracts Team on 0845 600 1980

Waterloo Primrose Hill Guildford Manchester

www.cphartboutique.co.uk www.cphart.co.uk